

- 5) Clamp the Fairing to the Strut using two clamps. Shift the Fairing slightly to get a good fit with the Wing. You may have to trim the fairing to get a good fit.
- 6) When a good fit to the Wing and a snug fit around the Strut is attained, mark two holes with a 1/4" edge distance at the top and bottom in the flange of the Fairing. Drill #30 holes. If the bottom of the Fairing is slightly crooked remove it now and trim. Replace Fairing and cleco. Figure 24.4.3.

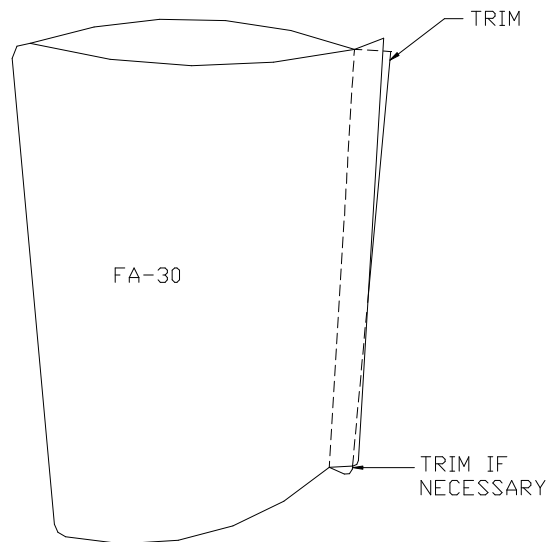

Fig. 24.4.3

- 7) Mark two more holes equal distance between the existing holes and drill #40. Deburr and rivet (RV-1410) together.
- 8) Slide the Fairing snug up against the Wing making sure it is tight against the Leading Edge side of the Strut. Drill two #32 tap drill holes on opposite sides of the lower end of the Fairing and put in two sheet metal screws. Figure 24.4.4.