

10.14 Installing Flaperon Horns

- 1) Slide a 2" washer (M2W) and a 1/2" spacer (CC-54) onto the torque tube root end.
- 2) Ensure that the torque tube is pulled rootward and the 1/2" sleeve (CC-54) is against the 2" washer (M2W), then drill eight equally spaced #11 holes through the spacer and tube 1/2" from the end.
- 3) Deburr end of the torque tube and sleeve.
- 4) Slide a sleeve (CC-100) over the end of the tube and an end plug (EL-31) into tube.

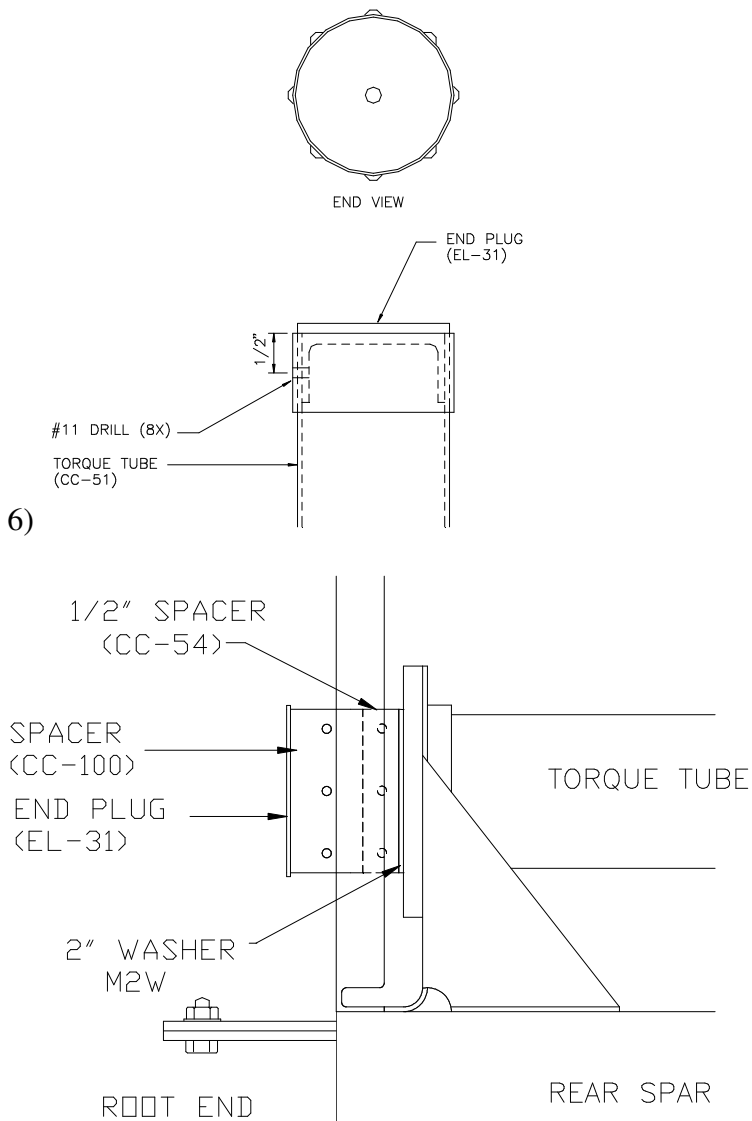

Figure 10.14.1

- 7) Disassemble and deburr.
- 8) Make a push-pull tube (CC-82) from 3/4" x .035 tubing (CC-51) as in figure 10.14.2.

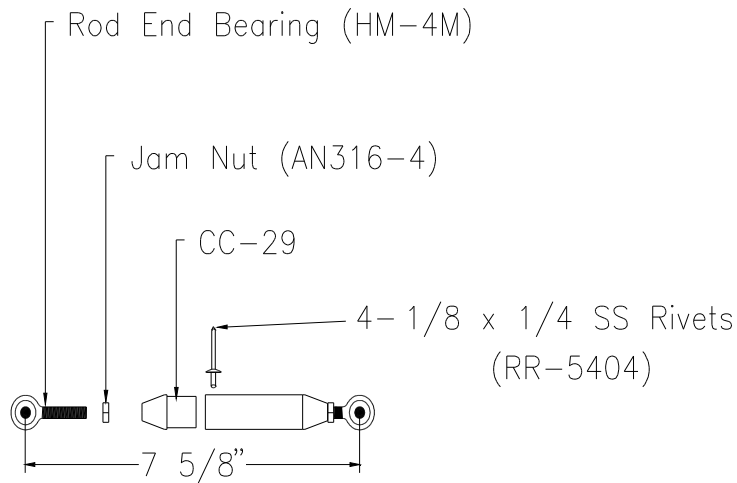

Figure 10.14.2

9) Attach push-pull tube (CC-82) to the control horn (CC-43) with an AN4-11A bolt, AN970-4 washer and an AN365-428 fibernut. Figure 10.14.3.

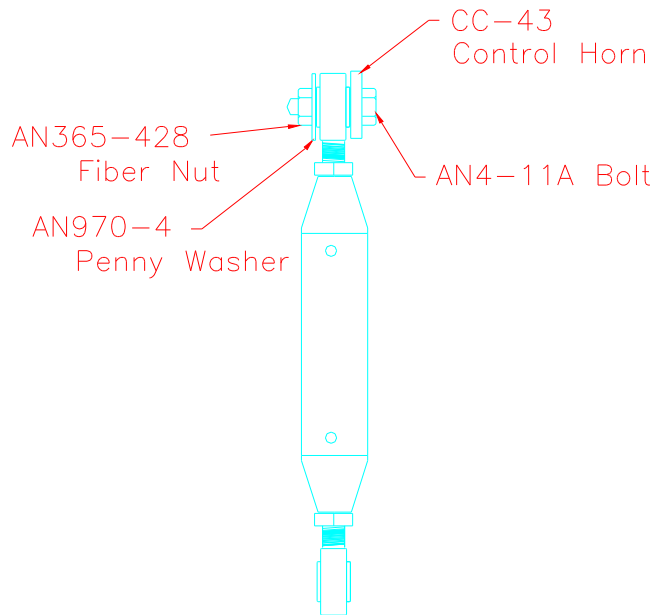

Figure 10.14.3

10) With the flaperons in neutral position attach the other end of the push-pull tube (CC-82) to the flaperons with an AN4-13A bolt, AN960-416 washer and AN365-428 fibernut. Figure 10.14.4.

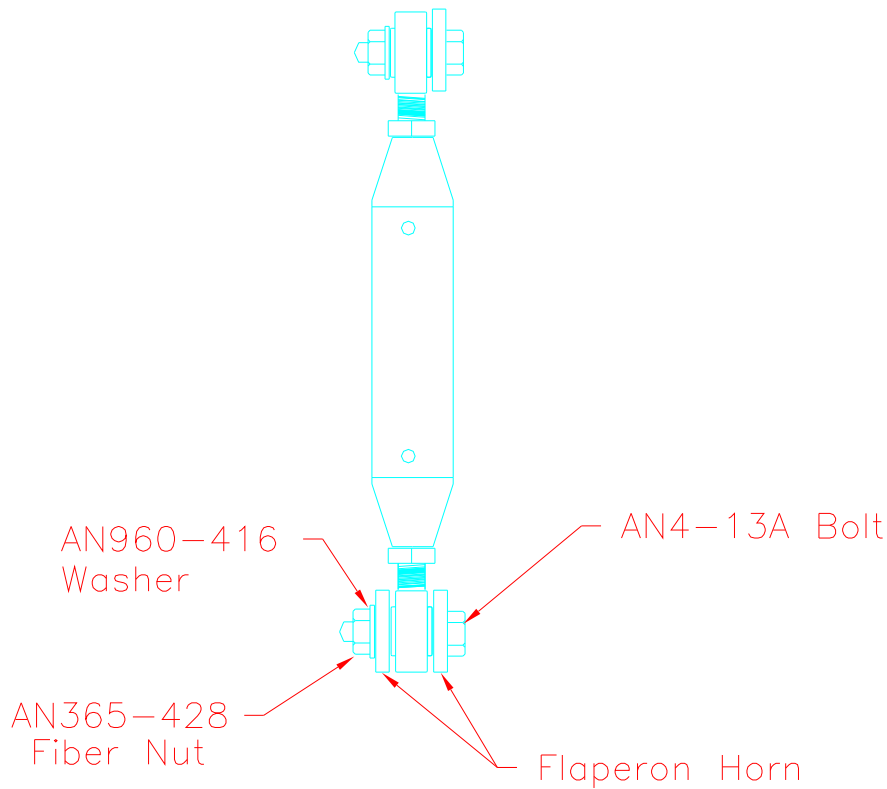

Figure 10.14.4

- 11) Ensure flaperon still has 20° up deflection and 40° down deflection.
- 12) Set flaperon so it is at 20° up deflection.
- 13) Bolt, (allowing some movement) a control horn (CC-43) to the end plug at the root end of the torque tube. Securely cleco together all parts fitted in step 250. Adjust control horn (CC-43) so that it clears the bottom of the wing by 1/2". Figure 10.14.5.

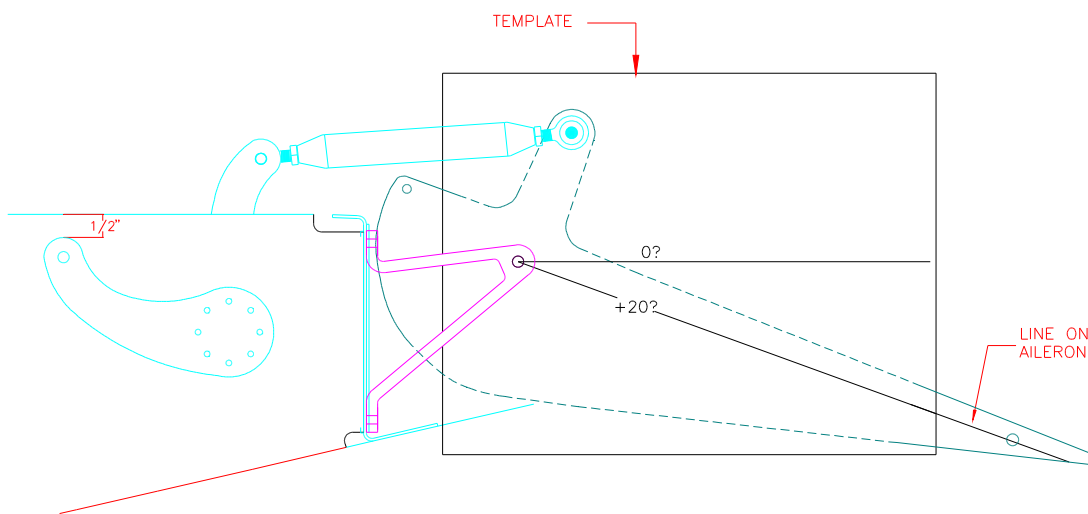

Figure 10.14.5

- 14) Drill eight #11 holes through control horn into the end plug. Figure 10.14.6.

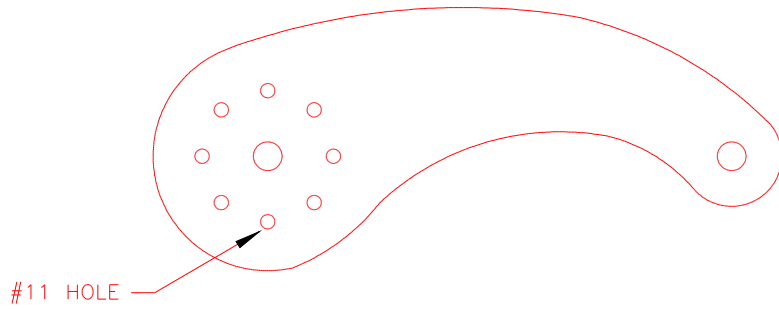

Figure 10.14.6

15) Remove and deburr parts.

16) With suitable 1/4" hardware, temporarily bolt another control horn (CC-43) onto the root control horn. Figure 10.14.7.

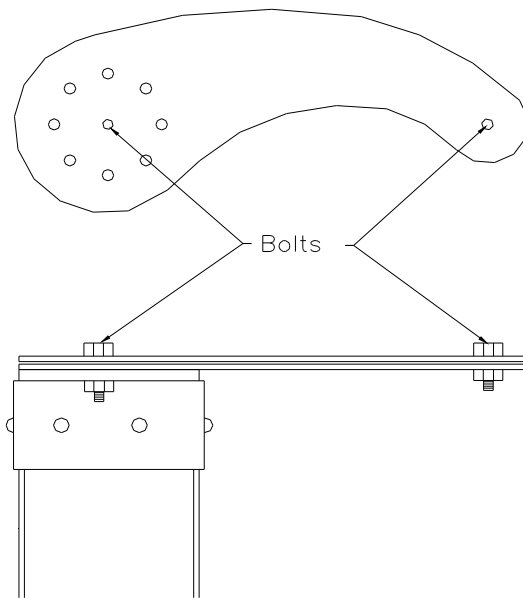

Figure 10.14.7

17) Drill a #11 hole through both parts approximately 1 1/2" from the end hole. Remove temporary bolts. Mark and store matched horn. Store the drilled horn. Deburr parts, chromate mating surfaces and rivet previously fitted root control horn and associated parts with sixteen 3/16" x 3/8" SS rivets (RV-5606). Figure 10.14.8.

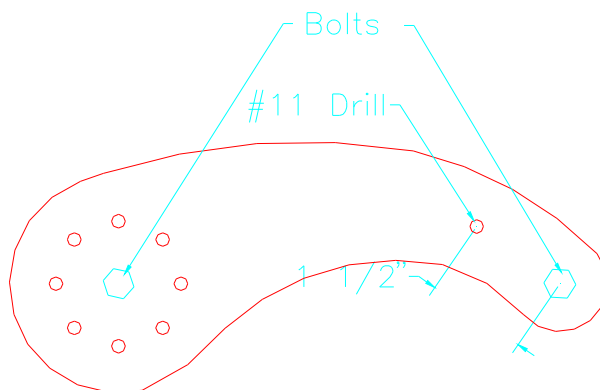

Figure 10.14.8

18) Bolt the horns together.