

## Elevator Assembly

To assemble the SR3500 Elevator, you will need the following tools:

1. Drill
2. Tape Measure
3. Felt Marker
4. #40, #30, 3/16", #11 Drill Bits
5. #40, #30 and 3/16" Clecos
6. Cleco Pliers
7. Two 3/8" Wrenches
8. Aviation Snips
9. Riveter
10. Fluting Pliers or Stretcher/Shrinker
11. 4' Level
12. Square
13. Masking Tape
14. 1/4" Round File and Flat File

# SR3500 ELEVATOR ASSEMBLY

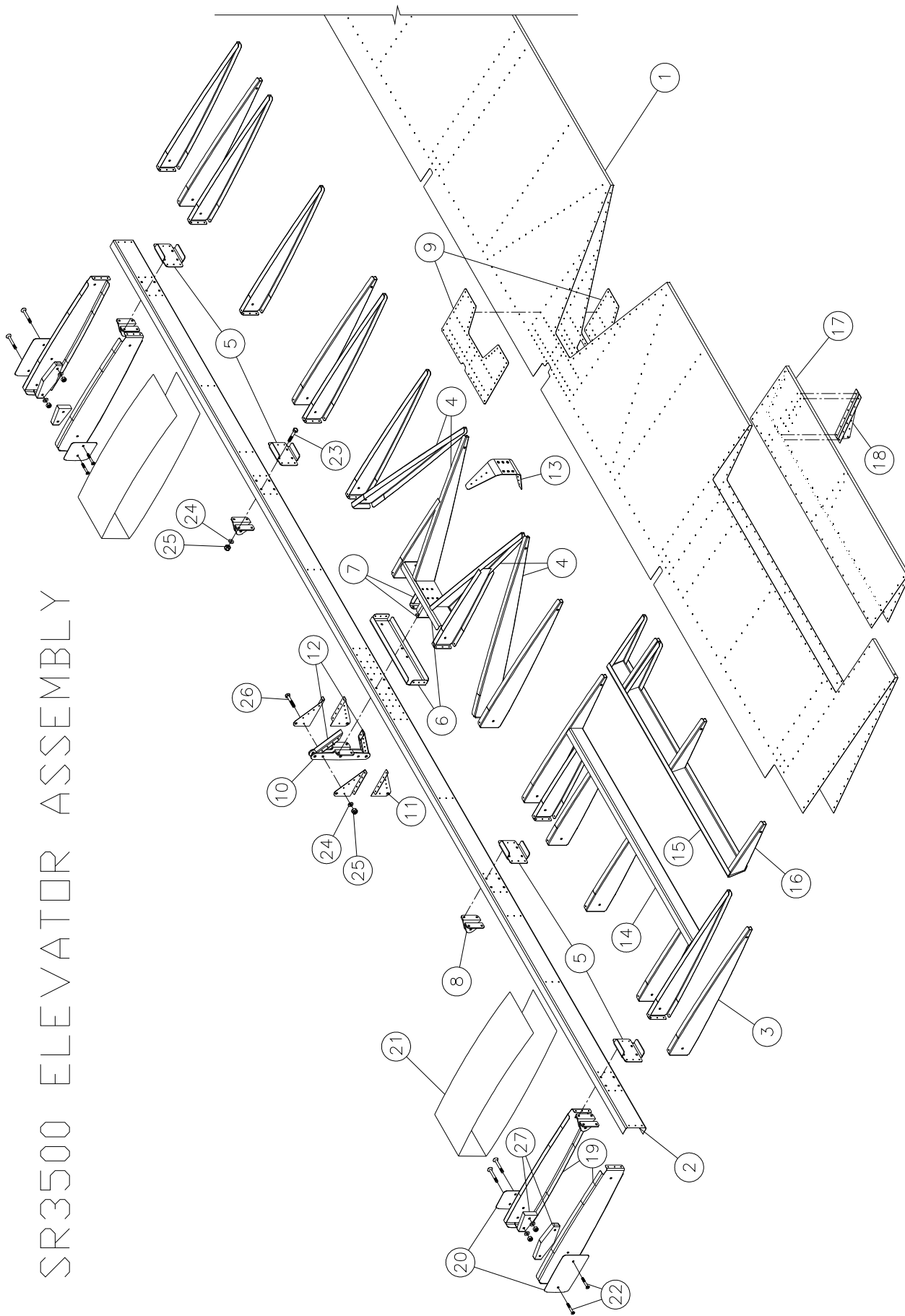

## Elevator Parts List

#	DESCRIPTION	PART NUMBER	QTY SHIPPED
1	ELEVATOR SKIN	EL0310	1
2	ELEVATOR SPAR	EL0309	1
3	ELEV/RUD RIB	EL0303	17
4	ELEV/RUD RIB DIAGONAL	EL0450	4
5	ELEV/RUD HINGE DOUBLER	EL0307	4
6	ELEV CENTER DOUBLER	EL0304	2
7	STIFFENER RIB	EL0312	2
8	ELEV/RUD HINGE	EL0300	8
9	ELEV CENTER GUSSET	EL0451	2
10	ELEV/RUD HORN	EL0301	2
11	ELEVATOR HORN DOUBLER*	EL0454	1
12	HORN DOUBLER SPACER*	EL0453 (0.625" SQ TUBE 0.035Tx10")	
13	HORN STRAP	EL0452 (0.040T 2.5"x11" )	
14	FRONT TRIM SPAR	EL0314	1
15	REAR TRIM SPAR	EL0315	1
16	TRIM RIB	CUT FROM EL0303	
17	TRIM SKIN	CUT FROM EL0310	
18	TRIM HORN*	EL1001	1
19	TIP RIB	EL0402	2
20	TIP WEIGHT BACKING PLATE*	EL0412	1
21	ELEVATOR TIP SKIN	EL0313	2
22	MACHINE SCREW	AN509-1032 R16	8
23	BOLT	AN3-5A	20
24	WASHER	AN960-10	60
25	FIBER NUT	AN365-1032	30
26	BOLT	AN3-10A	2
27	ELEVATOR TIP WEIGHT	EL0037	3

## PARTS NOT SHOWN

	PIANO HINGE	1419-D00SS	1
	3/16" x 1/4" AVEX RIVET	RV-1613	10
	1/8" x 3/16" AVEX RIVET	RV-1410	2500
	MACHINE SCREW FOR SERVO	AN525-832 R10	4
	WASHER FOR SERVO	AN960-8	4
	FIBER NUT FOR SERVO	AN365-832	4
	ELEV/RUD INSPECTION COVER	EL0409	4
	SERVO BACKING PLATE	EL0316	1
	CRUSH TUBE	EL0032	1
	ELEVATOR TIP WEIGHT	EL0037	3
	REINFORCING ANGLE	ST0040 (24")	1

\* Cut from the part or raw stock

### 3.1 Doublers

- 1) Layout all the parts as in the exploded view. **NOTE:** Do not handle the Elevator Skin (EL0310) until it is needed during assembly.
- 2) Using the four 3/16" holes, cleco the Elevator Center Doubler (EL0304) to the center of the Elevator Spar (EL0309). Drill all #40 holes into the doubler that are within the area of EL0304, using EL0309 as a guide. Drill these #40 holes to #30. Figure 3.1.1.

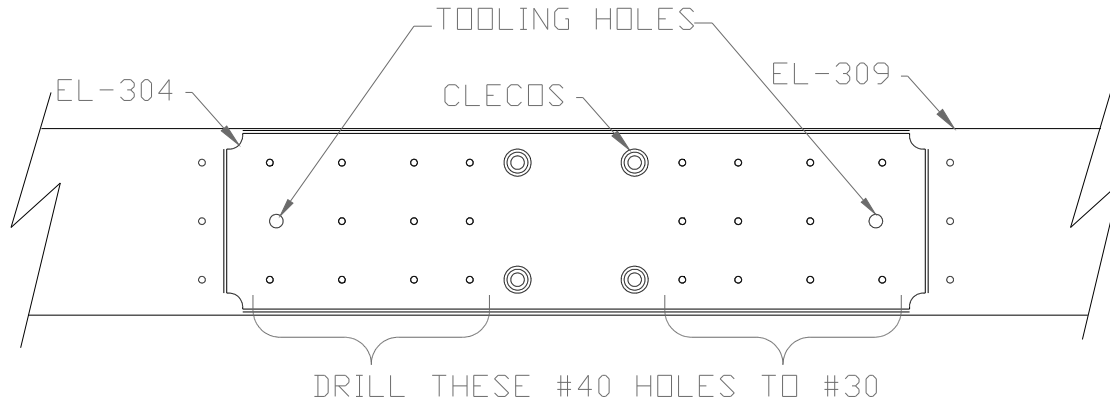

Figure 3.1.1

- 3) Remove EL0304 from EL0309. Debur the holes.
- 4) Chromate the two mating surfaces and rivet the two parts together using 1/8" avex rivets (RV01410). **NOTE:** Rivet from the Spar side to the Doubler.
- 5) Cleco the four Elevator Hinge Doublers (EL0307) to the Elevator Spar (EL0309) using the four 3/16" holes that are in the Elevator Hinge Doublers. Figure 3.1.2.

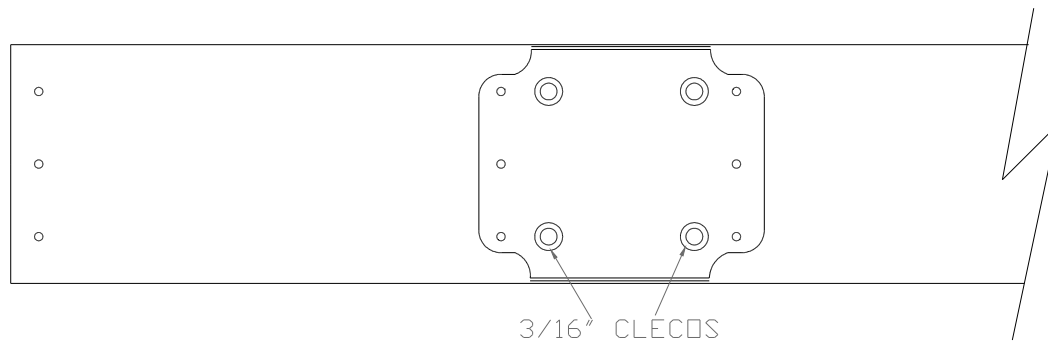

Figure 3.1.2

### 3.2 Rib Install

- 1) Cleco the Elev/Rud Ribs (EL0303) and Tip Ribs (EL0402) to the Main Spar. The spar location for the EL0450 ribs that run diagonally between the No. 1 EL0303 location and No.2 EL0303 location will require the 3 #40 holes drilling in the spar for the rib flange attachment. Locate these 3 holes 1 3/16" inboard of the No.2 EL0303 location. Double check position from pre-punched holes in skin. Later kits will have these spar holes punched. **NOTE:** The ribs will need to be straightened so they lay flat on

the table. This can be done with fluting pliers or a Shrinker. If fluting pliers are used, ensure that the flutes that are made on the ribs are located between the rivet holes in the Skin. Cleco a Rib to one of the rib rivet lines in the Skin and mark the hole locations. Figure 3.2.1.

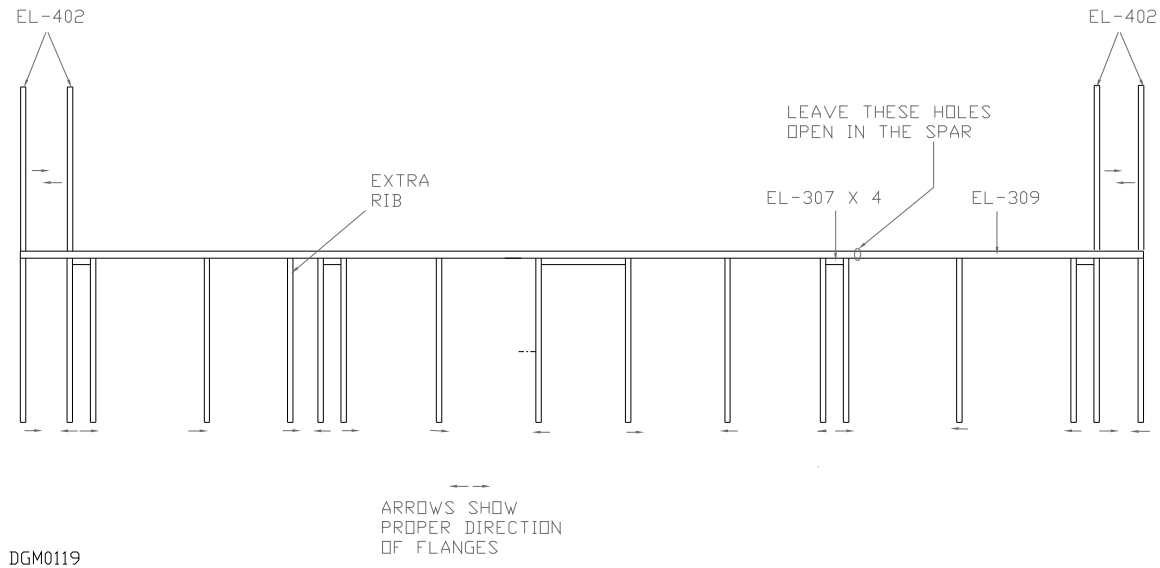
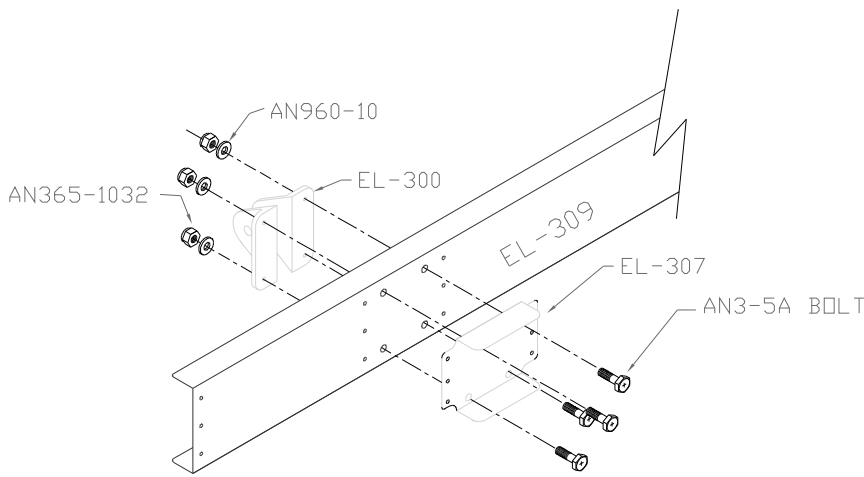

Figure 3.2.1

- 2) Drill the #40 holes that are common to the Main Spar, Elev/Rud Ribs , Tip Ribs and the Elevator Center Doubler to #30.
  - 3) Remove the Elev/Rud Ribs and Elev/Rud Hinge Doublers, mark centerlines on the top and bottom flanges of each rib. Debur the holes. NOTE: Mark the parts to ensure they are replaced in their correct positions.
  - 4) Chromate the mating surfaces of the Elev/Rud Hinge Doubler, and the Elev/Rud hinges (EL0300).
  - 5) Attach the end Elevator Hinge Doublers (EL0307), two Elev/Rud Hinges (EL0300) with AN3-4A bolt.
- Figure 3.2.2.



EDG401211

Figure 3.2.2

6) Chromate the mating surfaces of the Main Spar and the Elev/Rud Ribs. Rivet the ribs to the Main Spar with 1/8" avex rivets (RV-1410).

### 3.3 Skin Install

1) Take the Elevator Skin (EL0310) and cleco it to the spar assembly using the guide holes in the Elev/Rud Ribs that correspond to the Skin. **NOTE:** Allow the opposite side of the skin to over hang the table. Figure 3.3.1.

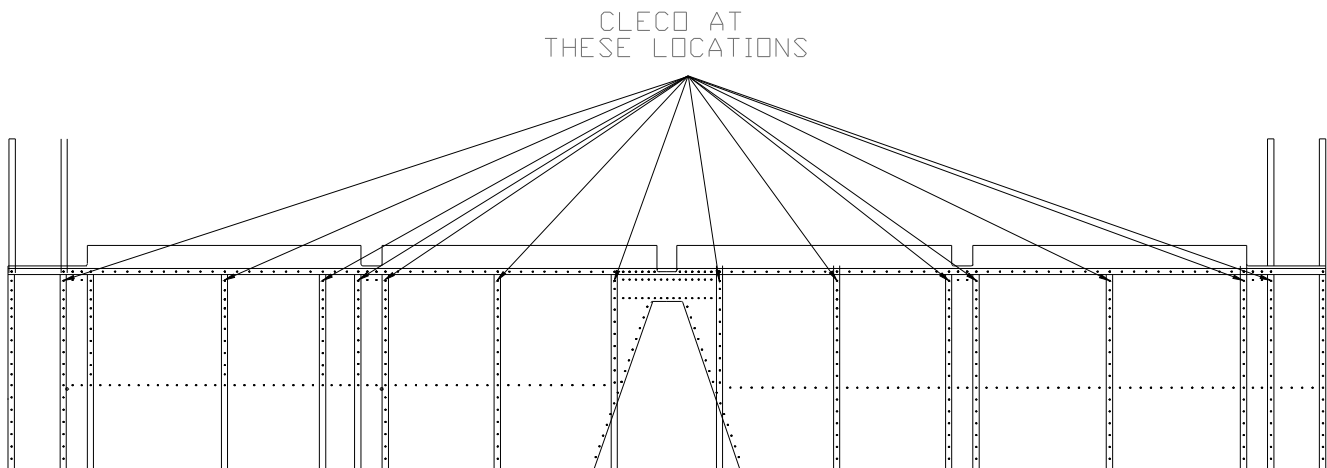

Figure 3.3.1

2) Working from the spar to the trailing edge and one hole at a time across the length of the Skin, drill #40 holes into the Ribs, keeping the line visible through the holes. Cleco.

**NOTE:** The center two ribs at the cut out and the ribs that are behind the trim tab will not have

rivets to the end of the ribs.

- 3) Place two 2" x 4" onto the table. Turn the skin and spar assembly over onto the 2" x 4"s so that the clecos do not interfere with the table. Figure 3.3.2. Drill and cleco the Skin to the ribs using the guide holes.

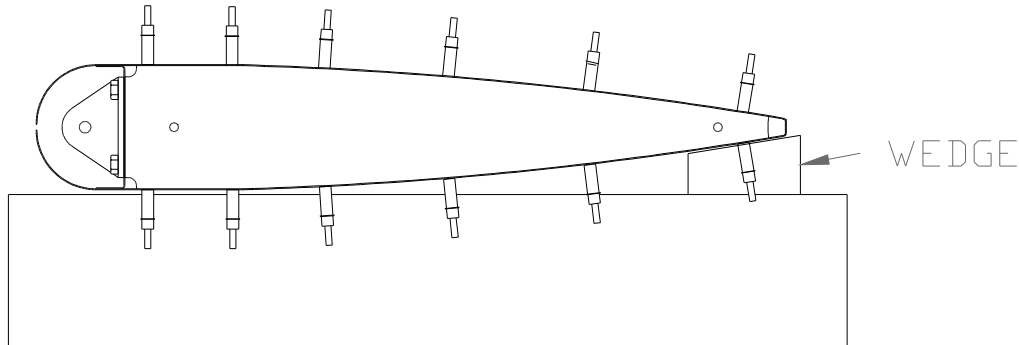

Figure 3.3.2

- 4) Level the assembly so there is no twist. Figure 3.3.3. **NOTE:** This is an important step to have done correctly. Please be careful on leveling. The distance along the trailing edge to the level should be the same along the length of the Elevator.

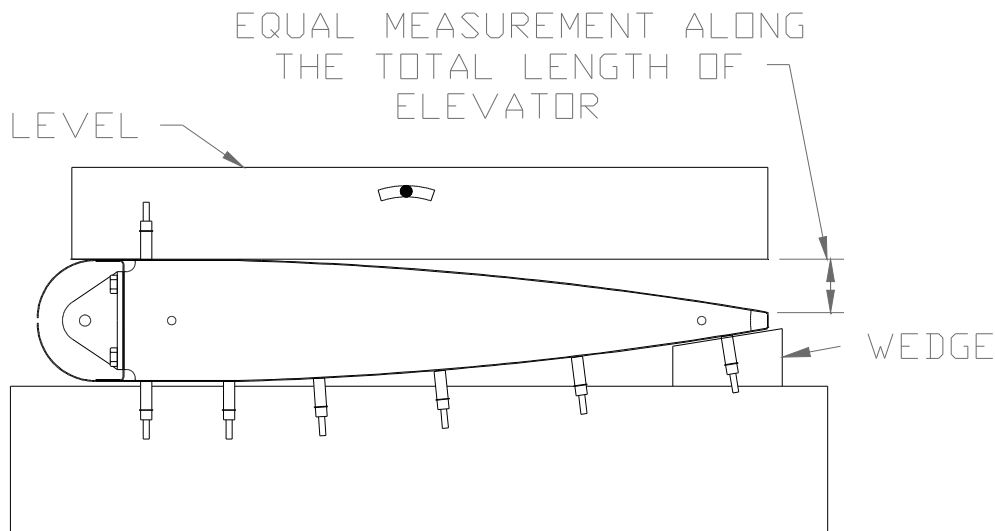

Figure 3.3.3

- 5) Drill the #40 holes into the Spar using the Skin as a guide. Cleco often.
- 6) Drill the #40 holes into the Hinge Doubler and Center Doubler, flip the assembly over and drill the Spar and Doubler to #40.
- 7) Drill all #40 holes that were drilled into the Doublers, Main Spar and Ribs to #30.
- 8) Remove the Elevator Skin and debur all the holes.

### 3.4 Stiffener Ribs

- 1) Mark the center two ribs  $5/16$ " from the last hole. Trim at this mark. Figure 3.4.1.

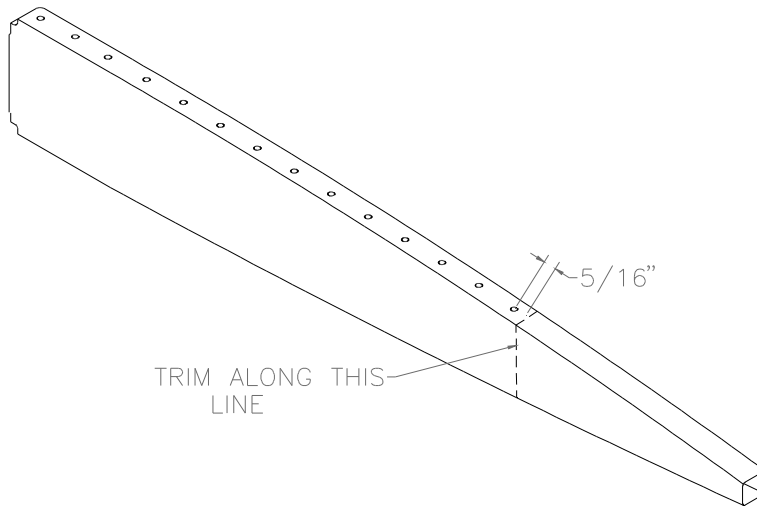

Figure 3.4.1

**NOTE:** Save the cut offs for use in the Trim Tab area.

- 2) Repeat the step for trimming the ribs behind the Trim Tab location.
- 3) Cleco the Elevator Skin onto the spar assembly (one side only). Figure 3.4.2.

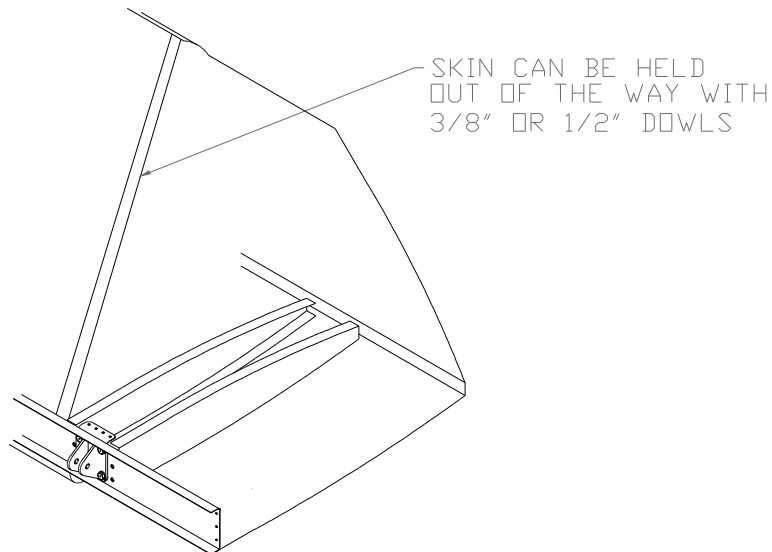

Figure 3.4.2

- 4) Mark the center of the top and bottom flanges of the second Elevator Center Doubler. Cleco the two EL0312 Stiffener Ribs to the Elevator Spar. Figure 3.4.5.



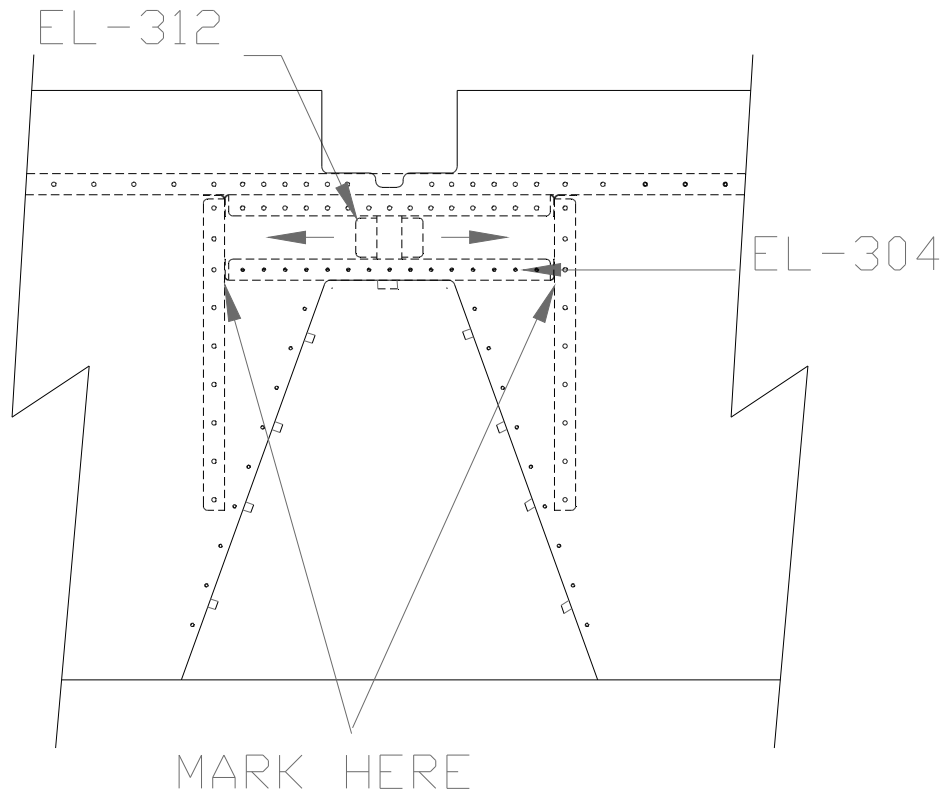

Figure 3.4.5

- 5) Cleco the second Elevator Center Doubler to the Stiffener Ribs. Mark the Elevator Center Doubler location onto the two center ribs. Figure 3.4.5. **NOTE:** Lower the Top Skin onto the center section to make sure the center line drawn on the EL0304 is visible through the pre-punched holes in the skin.
- 6) Prop the Skin open.
- 7) Center the Elevator Center Doubler along the height of the ribs on the marks that were drawn earlier.
- 8) Drill and cleco the three #40 holes from the Elevator Center Doubler into each rib.
- 9) Cleco the Elevator Skin onto the Spar Assembly and drill the #40 holes into the Elevator Center Doubler top and bottom flanges. **NOTE:** The center line should be visible through the holes in the skin.
- 10) Position an Elev/Rud Rib on top of the skin over the 'V' cut out so the trailing edge is parallel with the trailing edge of the of the other ribs. Mark the rib where it will need to be trimmed to fit against the center doubler. Figure 3.4.6

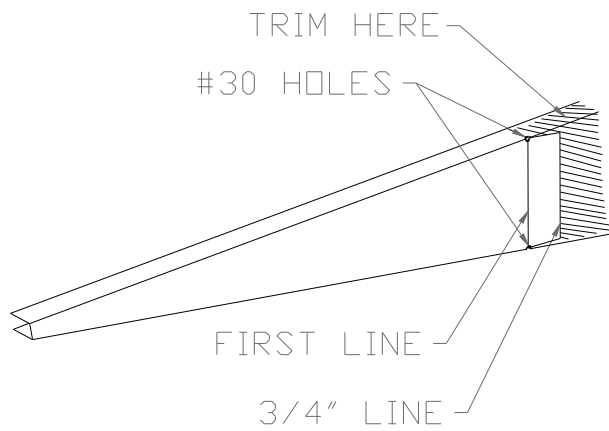

Figure 3.4.6

- 11) Mark a second line  $\frac{3}{4}$ " up from the first. Drill two holes in the corners at the first line. Trim at  $\frac{3}{4}$ " line as in figure 3.4.6.
- 12) Bend the flanges to match the Elevator Center Doubler.
- 13) Mark a line along the center of the upper and lower flanges of the rib.
- 14) Repeat steps for the opposite side rib.
- 15) Remove the clecos from one side of the Elevator Skin from the Spar Assembly and prop open.
- 16) Mark the Elevator Center Doubler, where the ribs will be placed. Figure 3.4.7.

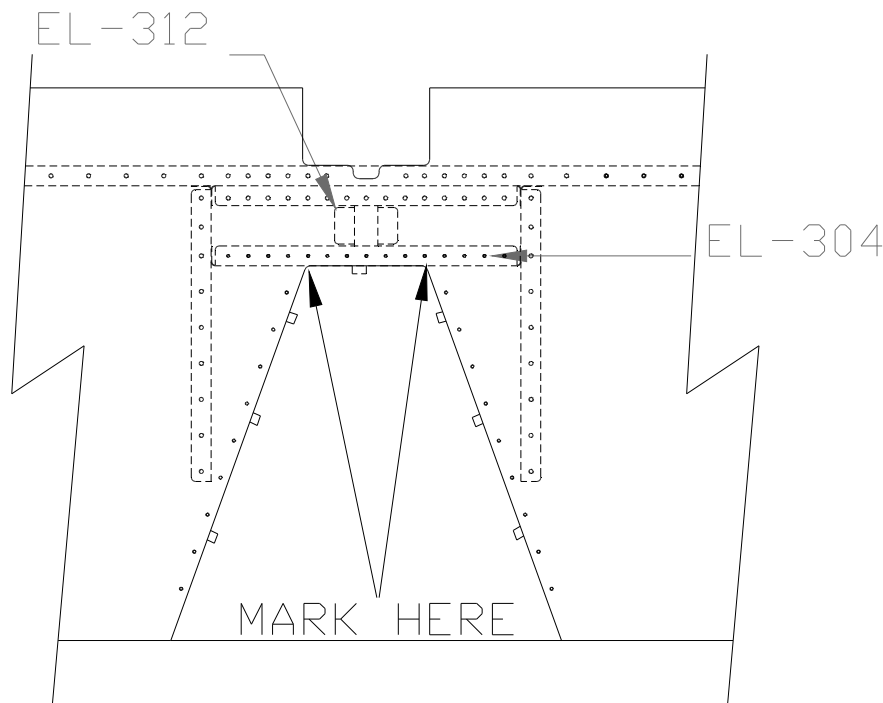
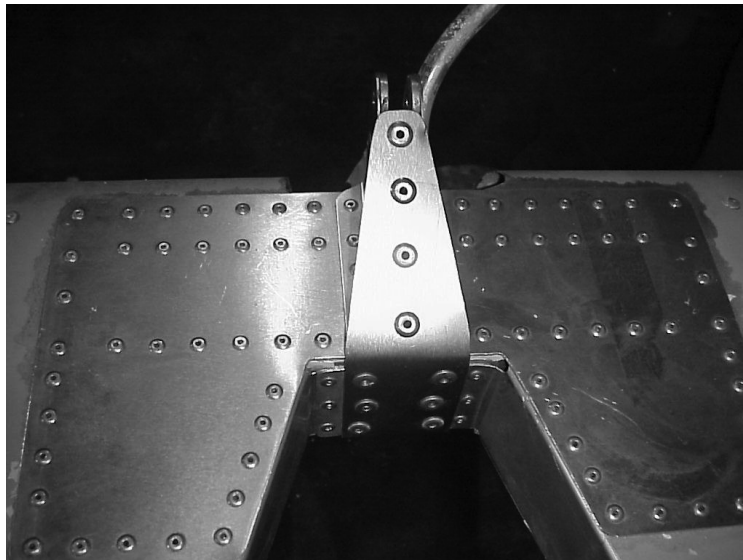
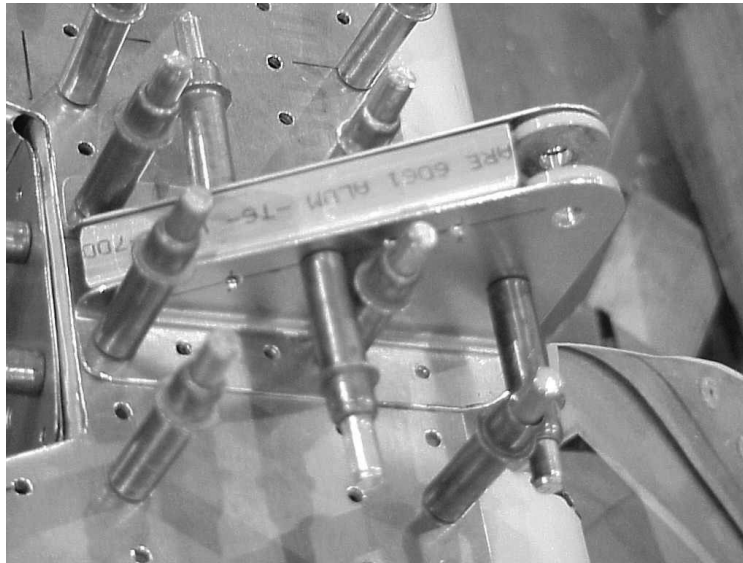

Figure 3.4.7

- 17) Remove the Elevator Center Doubler and position the rib where the rib location mark was made. Back Drill #40 holes through the Elevator Center Doubler into the rib. Repeat for the other rib. See figure 3.4.8 for rib placement.

- 18) Cleco together. Put it back into the elevator assembly.
- 19) Close the skin and drill through the #40 holes from the Skin into the rib. Make sure the center line on the rib flange is visible through the pre-punched holes.
- 20) Cleco the Elevator Center Gussets (EL0451) into place, top and bottom.
- 21) Mark the Elevator Spar top and bottom flanges at the center where they must be trimmed for the Elevator Horn clearance. (Use the Skin as a guide).
- 22) Trim the Elevator Spar for the Elevator Horn.
- 23) Drill all new holes to #30. Remove the Elevator Skin and deburr.
- 24) Drill all the new holes in the Elevator Center Doubler and the new center ribs to #30. Bolt the two Elev/Rud Horns (EL0301) to the center of the Elevator. Remove parts and deburr. Reassemble. Figure 3.4.8. Leave the center ribs and center gussets (EL0451) cleco'd in place.
- 25) Locate EL0454 horn doublers. Locate the horn doublers one on each side of the elevator horn. Using a hole finder, transfer the holes that lie under the flanges of the horn doublers to their flanges. Drill #30 and cleco in place. Trace around elevator horn, remove horn doublers and trim. Drill out a #11 hole 1" below the 1/4" hole that takes the cable bolt in both horns. Cleco one doubler back into place. Back drill the 1/4" cable bolt hole and the #11 hole in the horn into the horn gusset. Repeat for the other doubler. Drill all holes in the center gussets (EL0451) out to #21. Slide EL0453 tube in between doublers and drill 5 equally spaced #21 holes through each doubler into side of tube.
- 26) Locate strap material EL0452. Trim to shape, as in Fig.3.4.8. Slide this UNDER the tabs of the EL0450's, and back drill the holes. Add two more holes between the existing ones. Drill out to #11.
- 27) Slide the strap out, cleco into place on top of the tabs, and mark for the bend lines.
- 28) Bend the strap to fit, cleco back into place.
- 29) Drill four equally spaced #11 holes through the strap into the tube.
- 30) Take assembly apart, deburr, and rivet together:  
 EL0450's and EL0303's to skin with RV-1410; EL0450 center tabs and strap EL0452 with 6 X RV-1410's and six RV01613's; center doublers EL0451 with RV-1512's.  
 The #11 holes in the horns take an AN3-10A bolt and AN365-1032 fibernut, with AN960-10 washers used to space out between the horns.  
 Horn gussets to tube and center gusset with RV-1512's; strap EL0452 to tube with RV-1613's.  
 Repeat above steps for the other side of the elevator.



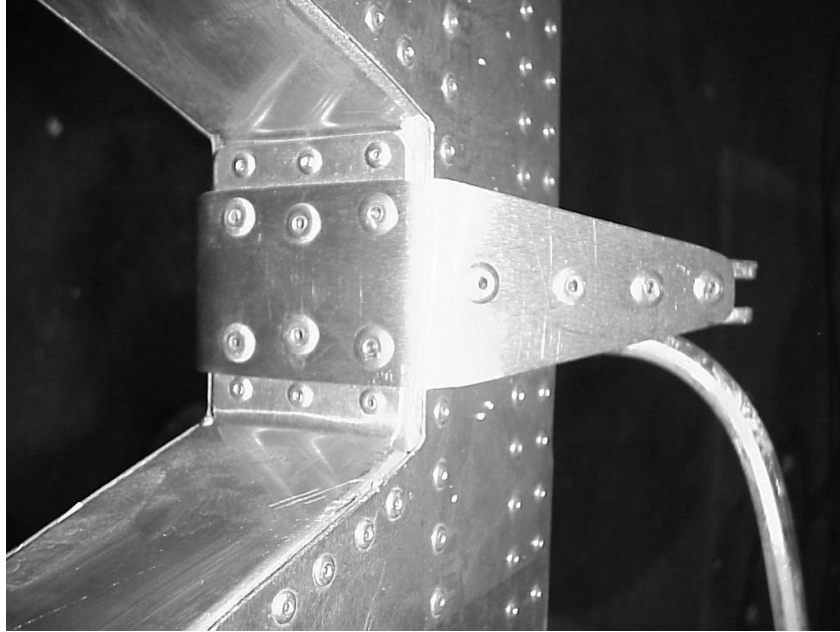

Figure 3.4.8

31) Cut out the Elevator Trim Skin along the tabs as in. Figure 3.4.9.

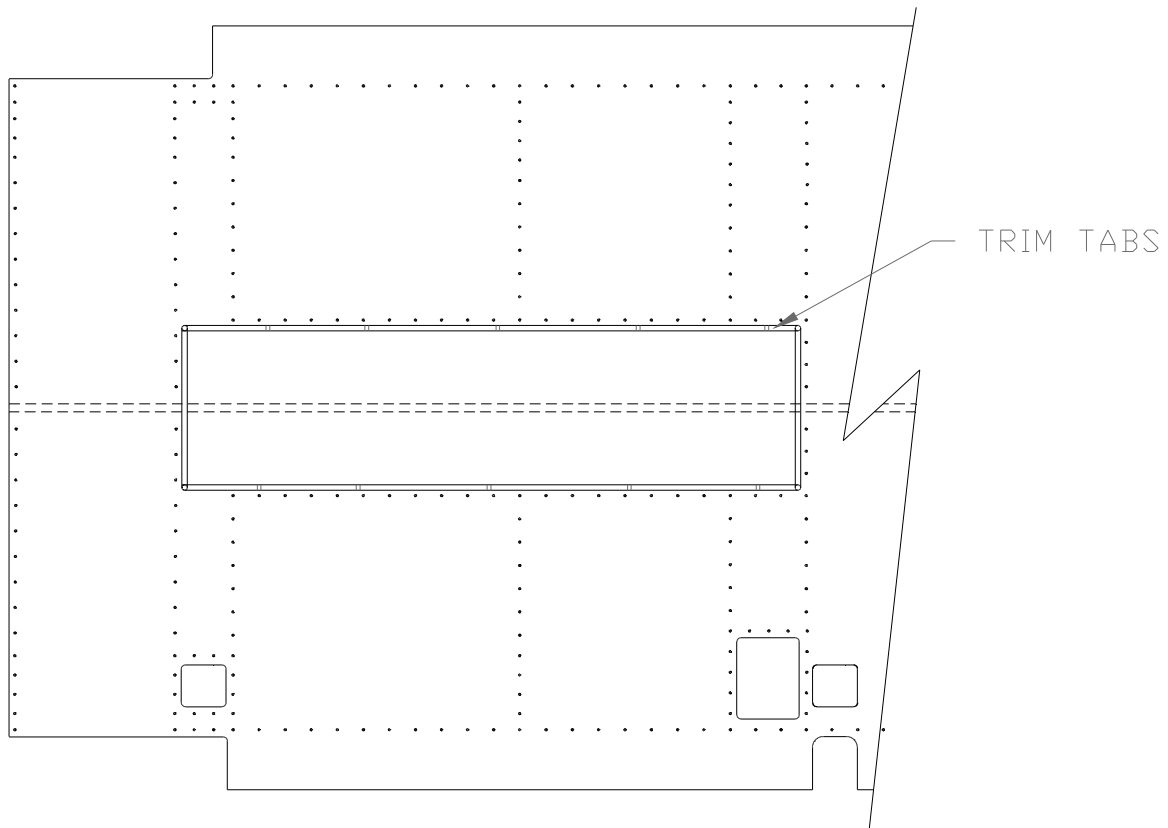
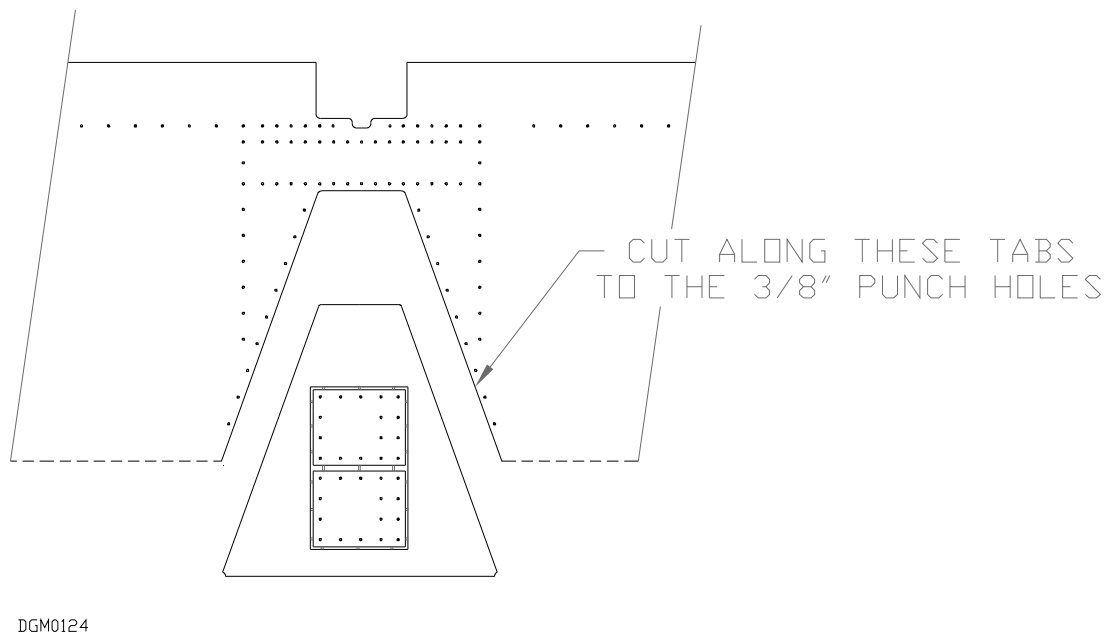

Figure 3.4.9

32) Set aside the Trim Skin. **NOTE:** Be careful handling the Elevator Skin so you don't crease it.

- 33) Trim the tabs that remain on the Elevator Skin off lightly and file the edges.
- 34) Debur the Elevator Skin.
- 35) Chromate all mating surfaces.
- 36) Cleco the skin onto the Elevator Spar assembly.
- 37) Rivet together using 1/8" avex rivet (RV-1410). Rivet only one side of the skin at this time, you will need to have the skin open to install the servo wiring later.
- 38) Cut the center from the Elevator Skin and smooth the edges with a file. Figure 3.4.10. Remove the inspection covers from the cut out and file smooth.



DGM0124

Figure 3.4.10

### 3.5 Trim Install

- 1) Trim the Front Trim Spar (EL0314) to fit between the two ribs at the trim location.
- 2) Trim a piece of Piano Hinge (1419 D00SS) 1/2" shorter than the Front Trim Spar. **NOTE:** Remove the hinge pin before cutting. Cut the hinge pin 3/4" longer than hinge.
- 3) Mark the center of the hinge material. Mark the center of the Trim Tab space.
- 4) Position the hinge material under the Elevator Skin so the two center lines match up. Drill the #40 holes from the Elevator Skin into the hinge material. Figure 3.5.1.

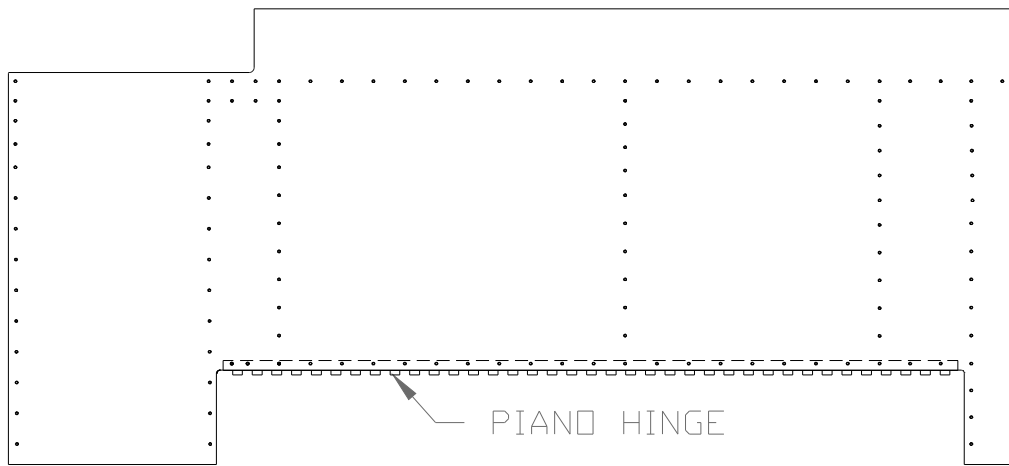

Figure 3.5.1

- 5) Remove and debur the hinge.
- 6) Draw a line along the center of the top and bottom flanges of Front Elevator Trim Spar.
- 7) Position the Spar so the line is visible through the #40 holes in the Elevator skin. Drill the #40 holes into the Front Elevator Trim Spar. Cleco.
- 8) Drill the #40 holes on the bottom side of the Elevator Skin into the Front Elevator Trim Spar.
- 9) Remove the clecos on the top side and insert the Piano Hinge between the Front Elevator Trim Spar and Elevator Skin. Cleco.
- 10) Drill the #40 holes out to #30.
- 11) Remove the Front Elevator Trim Spar and Piano Hinge .
- 12) Debur and cleco the Front Trim Spar, Piano Hinge and Elevator Skin together .
- 13) Trim the Elevator Trim Skin as in Figure 3.5.2.

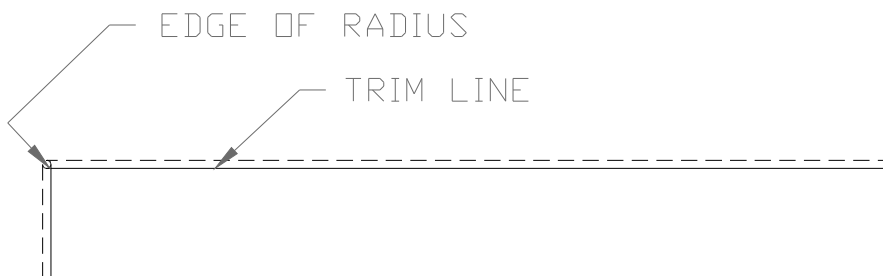

Figure 3.5.2

- 14) Match skin to hinge and drill #40 holes about 5/16 of an inch in from ends where the two lines intersect. Figure 3.5.3.

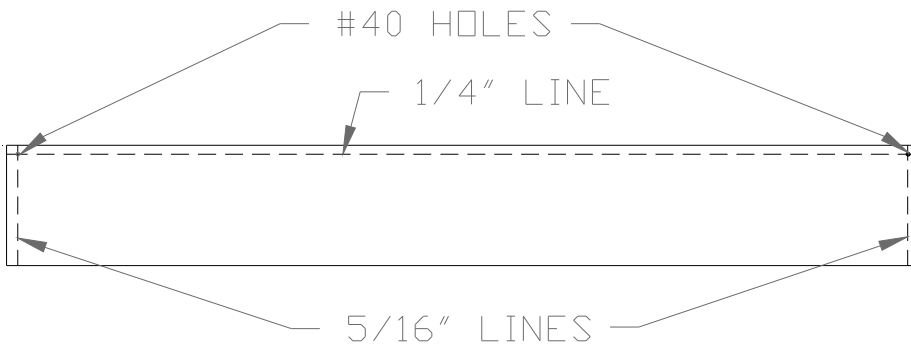

Figure 3.5.3

- 15) Between these two holes drill #40 holes at approximately 1 1/4" spacing.
- 16) Connect the second half of the hinge to the first with the hinge pin. Center the Trim Skin in the gap and drill the #40 holes into the hinge from the Trim skin. Figure 3.5.4.

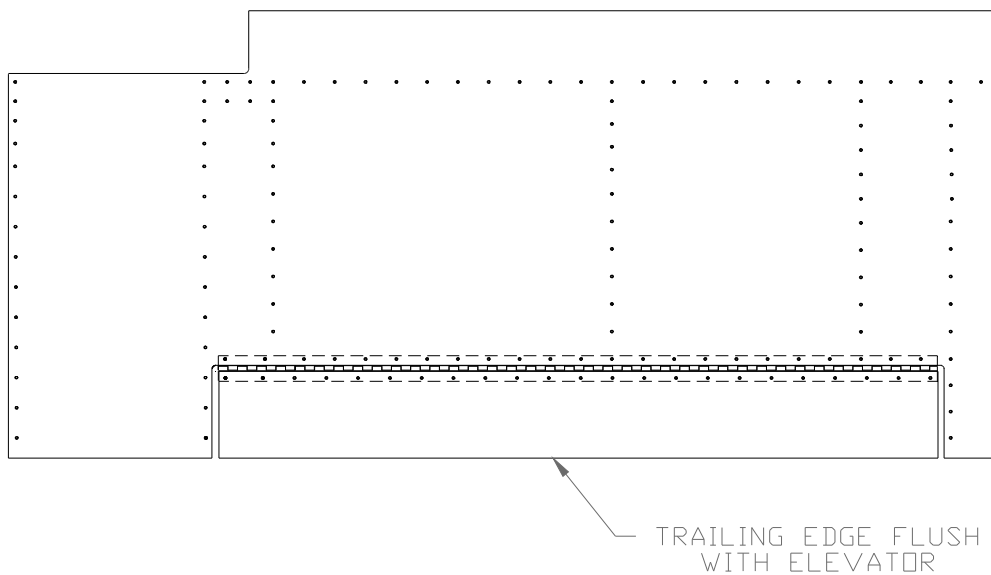

Figure 3.5.4

- 17) Remove the Trim Skin.
- 18) Position the Trim Rear Spar (EL0315) as in Figure 3.5.5.



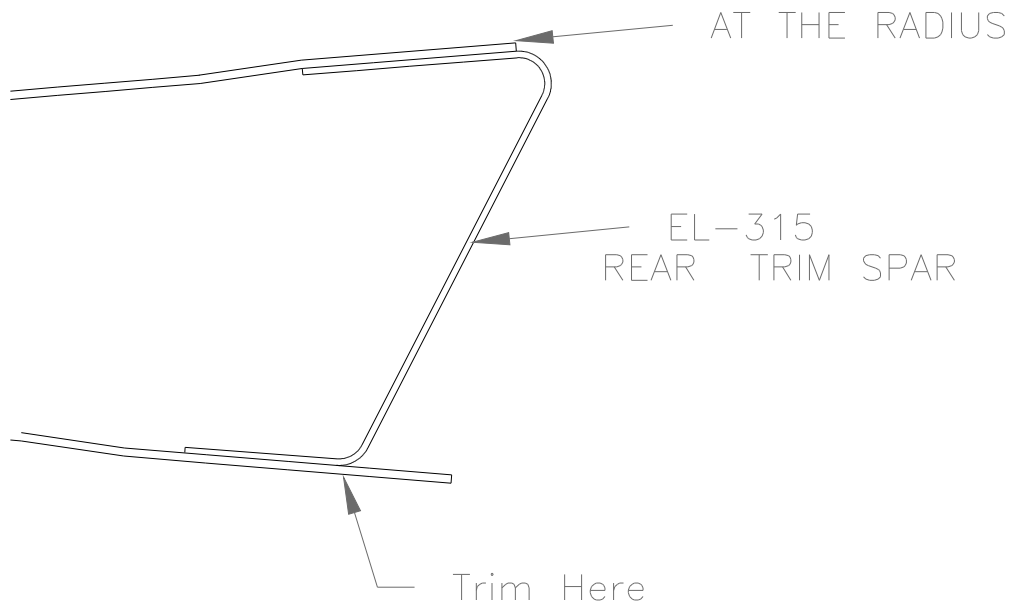
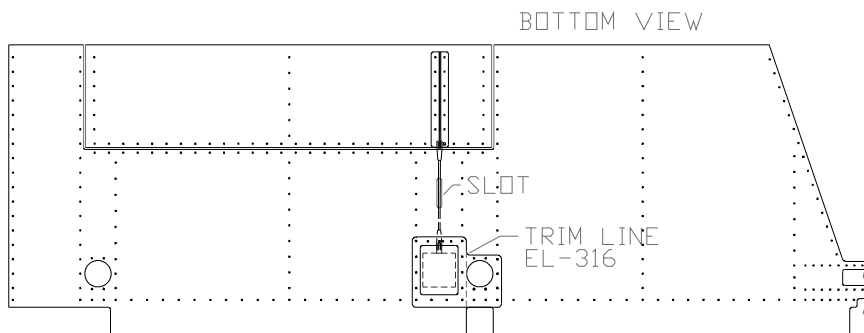

Figure 3.5.5

- 19) Drill the #40 holes from the Trim Skin into the Trim Rear Spar.
  - 20) Insert the Piano Hinge between the Trim Skin and Trim Rear Spar. Cleco.
  - 21) Using the Spar, mark a line where the skin will be trimmed. **NOTE:** Measure from the trailing edge to ensure that the line is square.
  - 22) Remove the Spar and Piano Hinge.
  - 23) Trim the skin along the line.
  - 24) Mark a line, 5/16" in from the three edges on the bottom skin for the spar rivet holes. Drill a #40 hole where the lines intersect.
  - 25) Between the two holes, along the line, drill #40 holes at an approximate spacing of 1 1/2" Figure 3.5.7.
  - 26) Cleco the Spar and hinge back onto the skin.
- Transfer the #40 holes from the skin into the spar clecoing as you go. Make sure Trim is flat.



{DGM0098}

Fig. 3.5.6

- 28) Disassemble and debur. Re-assemble with clecos.
- 29) Cut the trimmed piece of ribs from an earlier step so they fit between the spar and to the point where it does not distort the trailing edge. Do this for five ribs. **NOTE:** The flange direction of the middle rib is not important.
- 30) Using the same technique as you did in figure 3.4.6., make 90 degree flanges to pick up the trim tab spar. If this is not possible on all the offcuts, use a piece of angle(ST0040) to make the flanges.
- 31) With the trim skin/spar assembly in place, transfer rivet lines from elevator skin to trim tab skin. These lines now set your rib positions. Remove tab and transfer lines to front of spar and lower surface of skin. Ensuring you will pick up rib flanges, drill three equally spaced #40 holes at each rib position on spar.
- 32) Draw lines down all flanges of trim tab ribs, centered or as appropriate. Back drill through the holes you drilled in the spar into the rib flanges, and cleco in place.
- 33) In the trim tab skin, drill #40 holes along traced lines at 11/8 – 11/4 spacing as appropriate. Cleco skin to spar/rib assembly.
- 34) Back drill through #40 holes in skin into ribs, using the lines drawn in step 5 as a guide. Open up all holes to #30, deburr and cleco together. Try to complete step 34 with the trim tab trailing edge clamped to the elevator trailing edge.
- 35) Connect the Trim to the Elevator with the Hinge Pin, if you have not already done so.
- 36) With the Elevator on its back, check to ensure that the Servo Backing Plate (EL0316) fits to the holes in the skin. (It also doubles as one inspection cover).
- 37) Position the Servo on the Servo Backing Plate so it will fit into the hole provided in the skin. Using the Servo, drill the four mounting holes.
- 38) Mount the Servo to the Servo Backing Plate with four Screws (AN525-832 R10), four washers (AN960-8) and four nuts (AN365-832). **NOTE:** Make sure that the Servo is pointing the right direction.
- 39) Locate Trim Horns EL1001. Place the trim horns back to back and rivet together with 7 RV-1410 rivets. Drill a #30 hole in the front top corner of the trim horns to accept the fork of the trim motor push/pull tube.
- 40) Mount the Trim Horns to the trim skin with fourteen 1/8" avex rivets (RV-1410). Position so it is in line with the Servo output shaft. Figure 3.5.7.
- 41) Drill out a small slot in the Elevator Skin for the Push-Pull rod to exit from the Servo. Enlarge as needed to allow full travel of the Servo. Any 12 volt battery will allow you to cycle the Servo through its distance.
- 42) Locate EL0032. Cut to length, fill with proseal, and slide over threaded push/pull tube to strengthen it.

NOTE: Final adjustments should be made when installing to the airplane. Before closing up the skin, route the Servo wiring back through a hole in the Elevator Front Spar (use grommet in hole to protect wiring). Run the wiring inside the Elevator Leading Edge Skin and exit through the Control Horn opening.

### 3.6 Tip Install

- 1) Position the Elevator Tip Skin (EL0408) to the Outboard Tip Rib and Inboard Tip Rib. Figure 3.6.1.
- 2) Drill #40 holes from the Elevator Tip Skin into the Tip Ribs keeping the ribs flush with the skin.

Figure 3.6.1.

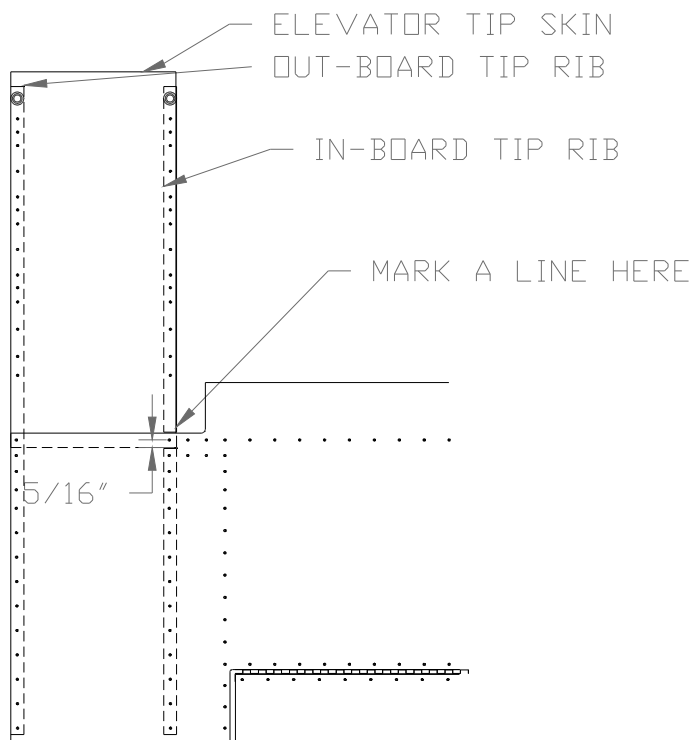
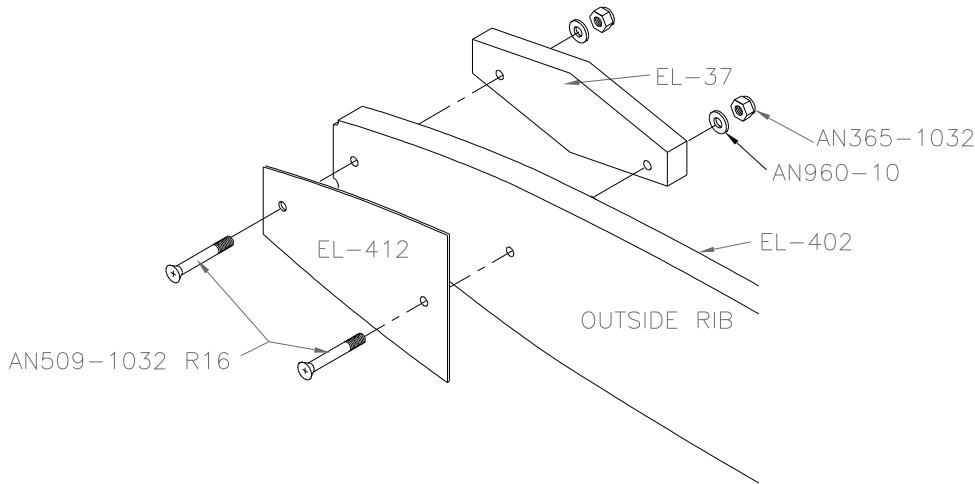

Figure 3.6.1

- 3) Keeping the line visible through the #40 holes in the Elevator Tip Skin, transfer the holes into the Tip Ribs. Cleco. **NOTE:** It is expected that what you do to the top side, you will do to the bottom side at the same time.
- 4) Remove the Tip Skin.
- 5) Drill all #40 holes to #30.
- 6) Replace the Tip Skin and drill #40 holes to #30.
- 7) Disassemble the Tip. Debur all parts.

- 8) Chromate the mating surfaces of the Ribs, Spar and Elevator Skin and cleco.
- 9) Using the Tip Rib as a jig, draw out the shape of the Tip Rib on the EL0412 Raw Stock supplied. Cut out two large pieces and two small pieces. Cut one of the Elevator Tip Weights in half. Place a whole weight on a larger piece of EL0412 and a cut weight on a smaller piece of EL0412. Drill two 3/16" holes through the weights and plates. **NOTE:** You can use the 3/16" tooling hole on the ribs as the location for one of the holes. Locate and drill the second 3/16" hole through the rib. Figure 3.6.2 and 3.6.3.



DGM0105

Figure 3.6.2

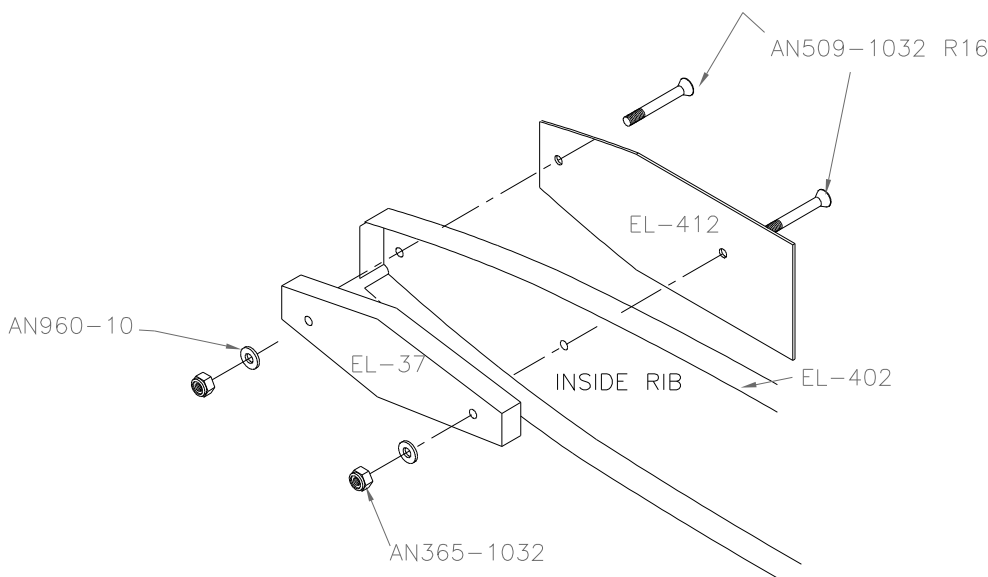

DGM0107

Figure 3.6.3

- 10) Assemble the tip weights and backing plates to the ribs as per figures 3.6.2 and 3.6.3.
- 11) Cleco the Tip Skin onto the Ribs.
- 12) Where the Tip skin overlaps the Spar and Elevator Skin, drill #30 holes at 1" spacing nominal.

Figure 3.6.4.

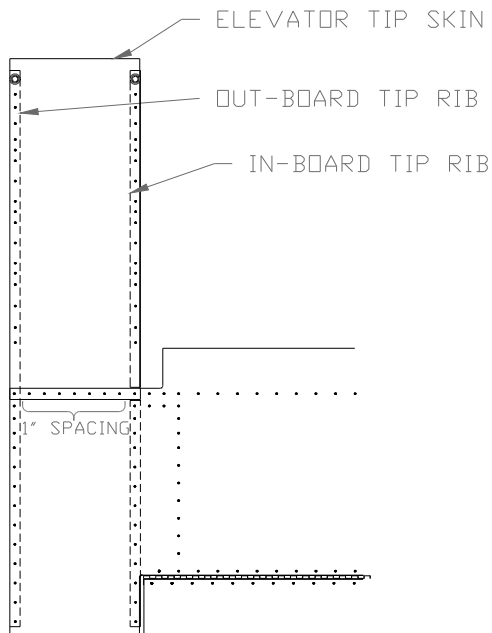

Figure 3.6.4

- 13) Disassemble and debur.
- 14) Chromate the mating surfaces and cleco.
- 15) Repeat steps for the other Elevator Tip.
- 16) Cleco the Inspection Covers in place. Drill the #40 holes to #30 and rivet to the Elevator Skin with 1/8" avex Rivets. **NOTE:** Stainless Steel screws or other suitable connectors can be substituted. For the Servo Backing Plate you can install floating anchor nuts for easy access.
- 17) Draw a line 1/2" from one edge of the Elevator Leading Edge. Pull the Leading Edge halves together with masking tape. The overlap should be a 1/2". Figure 3.6.5.

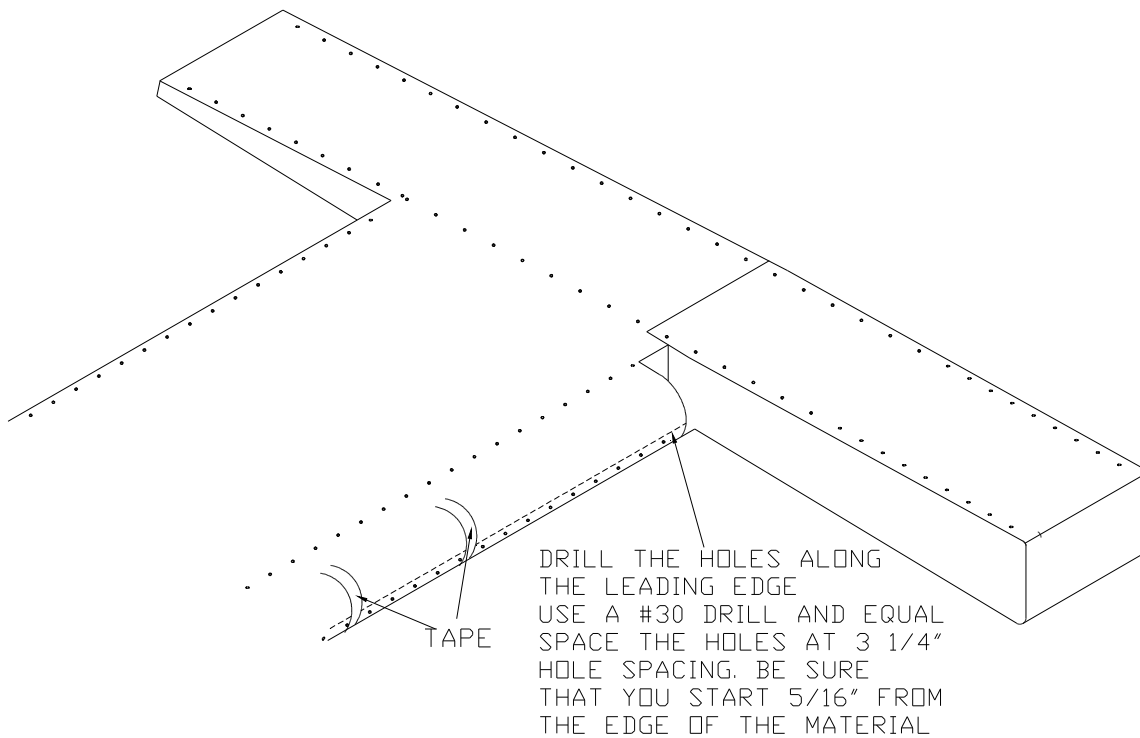

Figure 3.6.5

- 18) If you have installed the Servo wires you can now rivet the Elevator Skin with 1/8" rivets.
- 19) Drill holes along the Leading Edge to #30, using a 3 1/4" rivet spacing. Deburr, chromate and rivet together using 1/8" (RV-1410) avex rivets.